

2m Option:
 Solder C15a, C19a, C23a, C27a
 Do not solder C17, C21, C25
 Solder jumpers instead of C18, C26
 C14, C28: 3pF
 C22: 1pF
 L13, L15: 4.7uH

70cm Option:
 Do not solder C15a, C19a, C23a, C27a
 L13, L15: 1.5uH

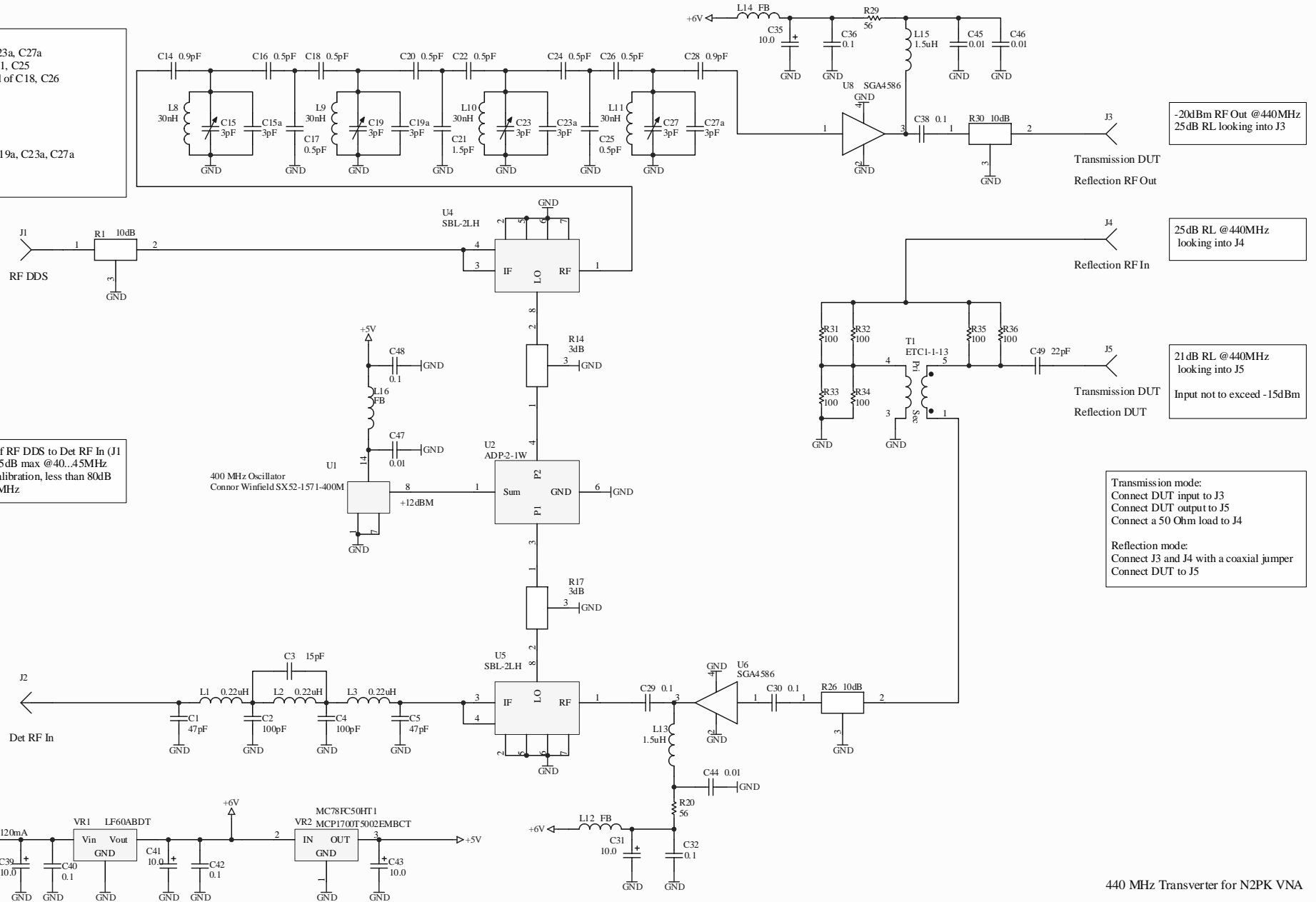

Transmission mode:
 Connect DUT input to J3
 Connect DUT output to J5
 Connect a 50 Ohm load to J4

Reflection mode:
 Connect J3 and J4 with a coaxial jumper
 Connect DUT to J5

440 MHz Transverter for N2PK VNA
 Ivan Makarov, VE3IVM